

Glasbearbeitung gilt für alle Modelle
 Glass machining valid for all models
 Preparazione lastre valida per tutti i modelli

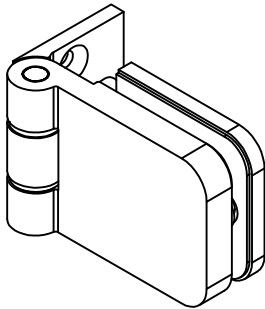

701A

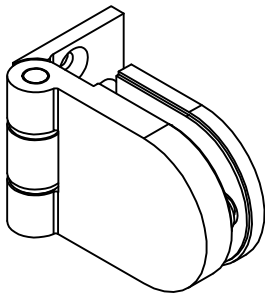
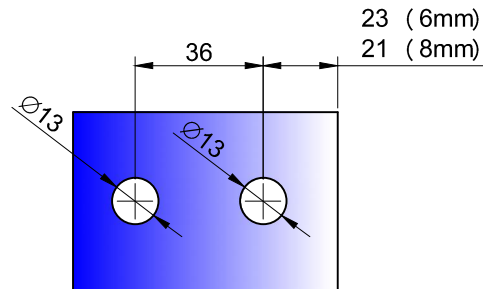

701B

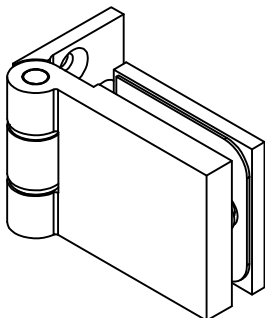
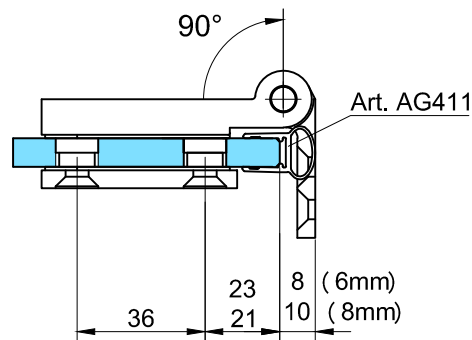

701C

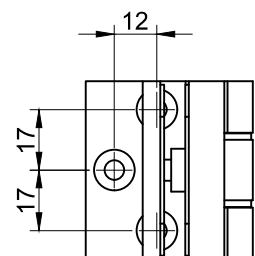
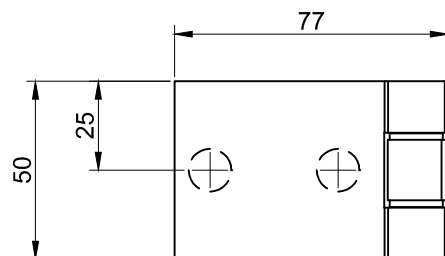

Artikel-Nr. Code Codice	Modell Model Modello	Material Material Materiale	Glasdicke Glass thickness Spessore vetro	Max Gewicht Max. Weight Carico max.	Max. Ladung Max. loading size Dimensioni max. Porta
C0007	701A	Aluminium / Messing Aluminium /Brass Alluminio /Ottone	6/8 mm	40Kg	1000xH1900 mm
C0008	701B	Aluminium / Messing Aluminium /Brass Alluminio /Ottone	6/8 mm	40Kg	1000xH1900 mm
C0009	701C	Aluminium / Messing Aluminium /Brass Alluminio /Ottone	6/8 mm	40Kg	1000xH1900 mm

Cod.	Oberflächenausführung Surface finish Finiture superficiali
CRO	Glanzverchromt Bright chrome Cromo lucido
CRS	"Scotch brite" verchromt Scotch brite chrome Cromo satinato
CRP	Matt verchromt Matt chrome Cromo perla opaco
ORO	Glanz Gold Bright gold Oro lucido
BRO	Bronze matt Satin bronze Bronzo satinato